

# Gaffco Ballistics, LLC

## Gaffco BDU-48 Nuclear, Biological, and Chemical Overpressure Filter/Ventilation System Installation & Operation Manual

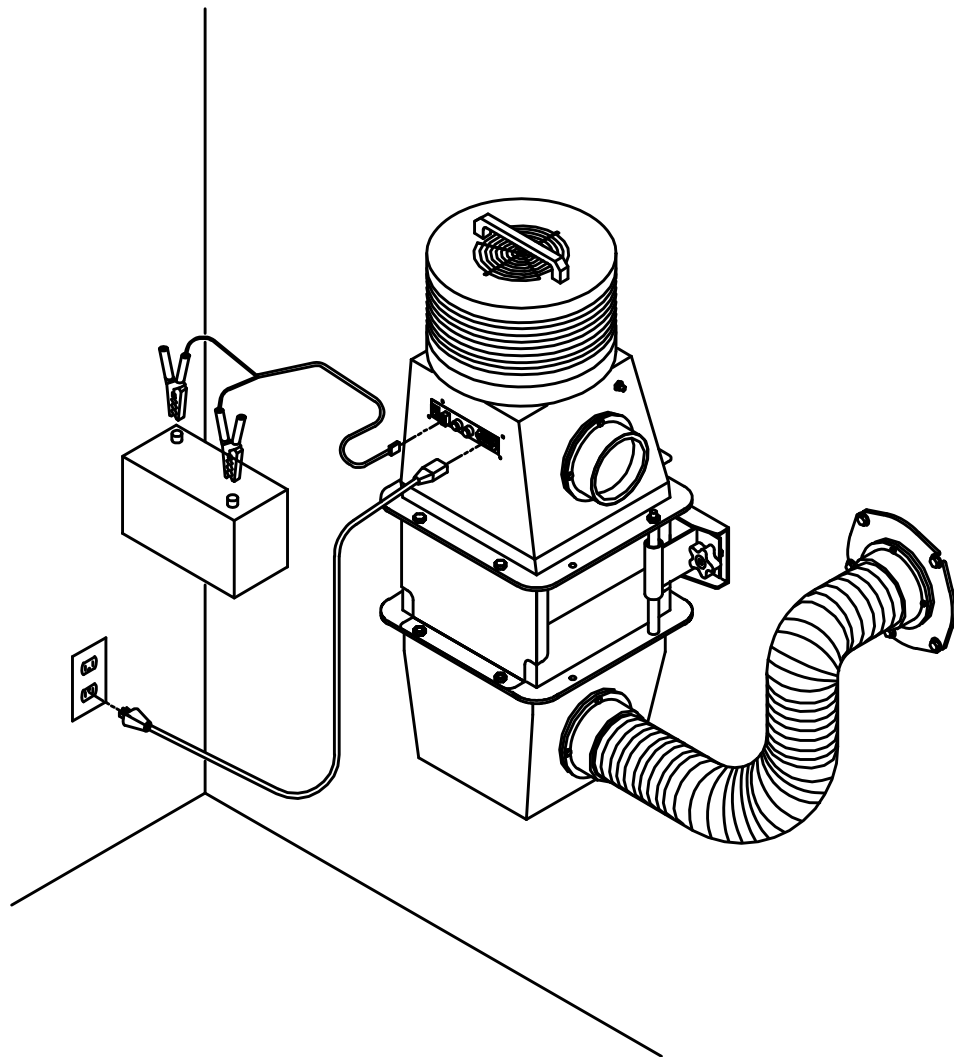

# Table of Contents

Contact information .....	A
Description .....	B
Installing the chemical adsorber .....	C
Wall mounting .....	D
Installation .....	E
Operation .....	F
How the BDU-48 works .....	G
Testing the system .....	H
Changing the filters .....	I
Optional hardware .....	J
Component dimensions .....	K
Specifications — general .....	L
Specifications — filters .....	L
Specifications — standards .....	L
Specifications — occupant ratings .....	L

# Contact



Gaffco Ballistics, LLC  
PO Box 2074  
South Londonderry, VT 05155

Tel: 802-824-9808  
Fax: 802-824-9910  
Email: [sales@gaffco.com](mailto:sales@gaffco.com)

## Description

The Gaffco BDU-48 is a portable, positive pressure, emergency air filtration system is designed to offer protection in the event of a nuclear, biological, or chemical event when installed in a protected space (room) with a maximum volume of 3,500 cubic feet (99 cubic meters). When properly installed, this system is capable of giving adequate supply of filtered air for up to 12 occupants, according to Israeli standards.

The system works by drawing outside air through its bank of six filter medias and introducing it into the protected space creating a slight overpressure (positive pressure). This overpressure is designed to deny access to any unfiltered air that would migrate back into the shelter area through small openings such as cracks or electrical outlets and conduit.

This overpressure relieves the occupants from wearing gas masks and protective clothing, enabling them a safe and comfortable environment.

The system operates from any standard 110-240 volt AC, 50/60 hertz power source.

In the event of a line power failure the unit has two emergency backup systems:

The first backup is an automatic switching power supply that trickle charges a user-supplied battery and then automatically draws power from that battery in the event of a power outage. In other words, if you were to “pull the plug” the blower will continue to operate and maintain an overpressure in your protected space. When the electricity comes back on line, it will automatically revert to drawing from the AC power and recharging the battery.

The second backup is an optional manual (hand pumped) blower that can be used in the event of a long-term power outage.



What's included with this filtration system:

- 1-each Gaffco BDU-48 filtration system
- 1-each wall mount bracket kit for the Gaffco BDU-48
- 1-each 110-VAC grounded power cord
- 1-each 12-VDC power cord with clip leads for a battery
- 1-each 60-inch air intake hose
- 1-each wall mount flange for the hose
- 1-each manual binder with all the relevant manuals
- 4-each cap plugs to seal the filter while not in use

# Installing the chemical adsorber

Your Gaffco BDU-48 filter/ventilation unit is shipped separate from the chemical adsorber.

To install the chemical adsorber, remove the two shipping bolts/nuts and the top end bell as shown in figure C-1.

**CAUTION** The face of the HEPA cell is now exposed and the media (pleats) are easily damaged.

Place the chemical adsorber carefully and squarely over the HEPA face shown in figure C-2. Ensure that the rubber seal surfaces of the filter gaskets are squarely mated as shown in figure C-3.

Set the top and bell over the stacked filter assembly taking care that the upper seal of the chemical adsorber is squarely seated inside the top end bell inner seal surface.

Sandwich the filter assembly with the two aluminum side plates and insert the 8 clamping bolts and nuts as shown in figure C-4.

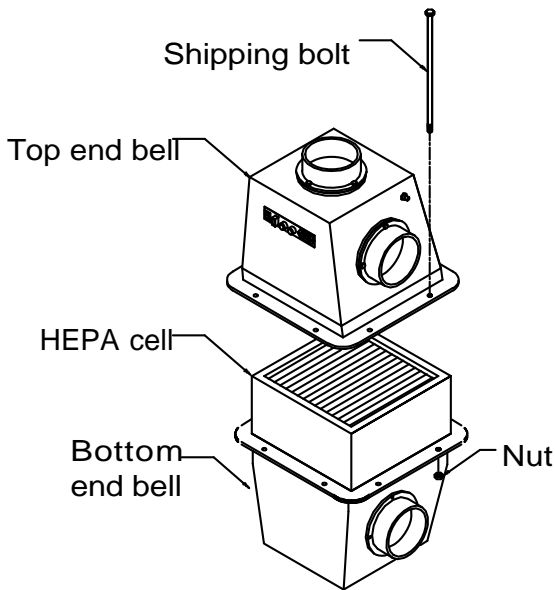

Figure C-1

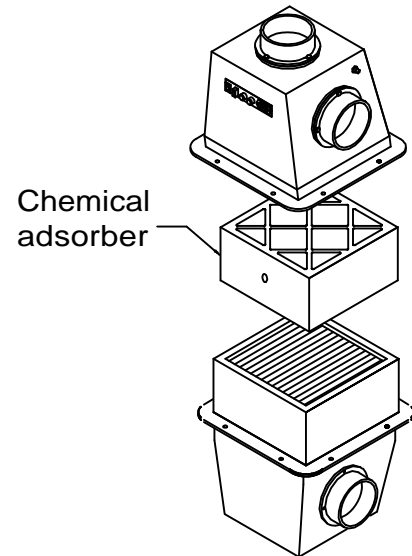

Figure C-2

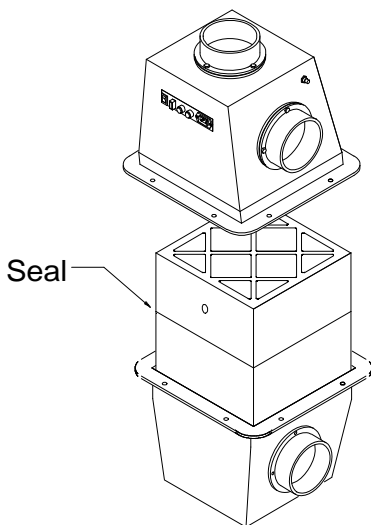

Figure C-3

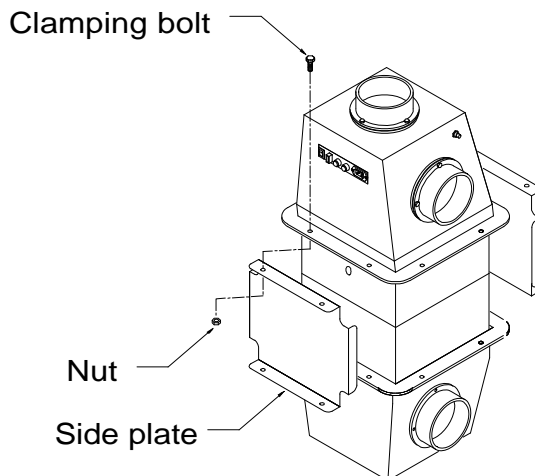

Figure C-4

# Wall mounting

The Gaffco BDU-48 comes with a quick-release wall bracket.

For ease of manual hand pump operation mount the Gaffco BDU-48 as low to the floor as possible.

The mounting location should be near an electrical outlet and within reach of the air-inlet.

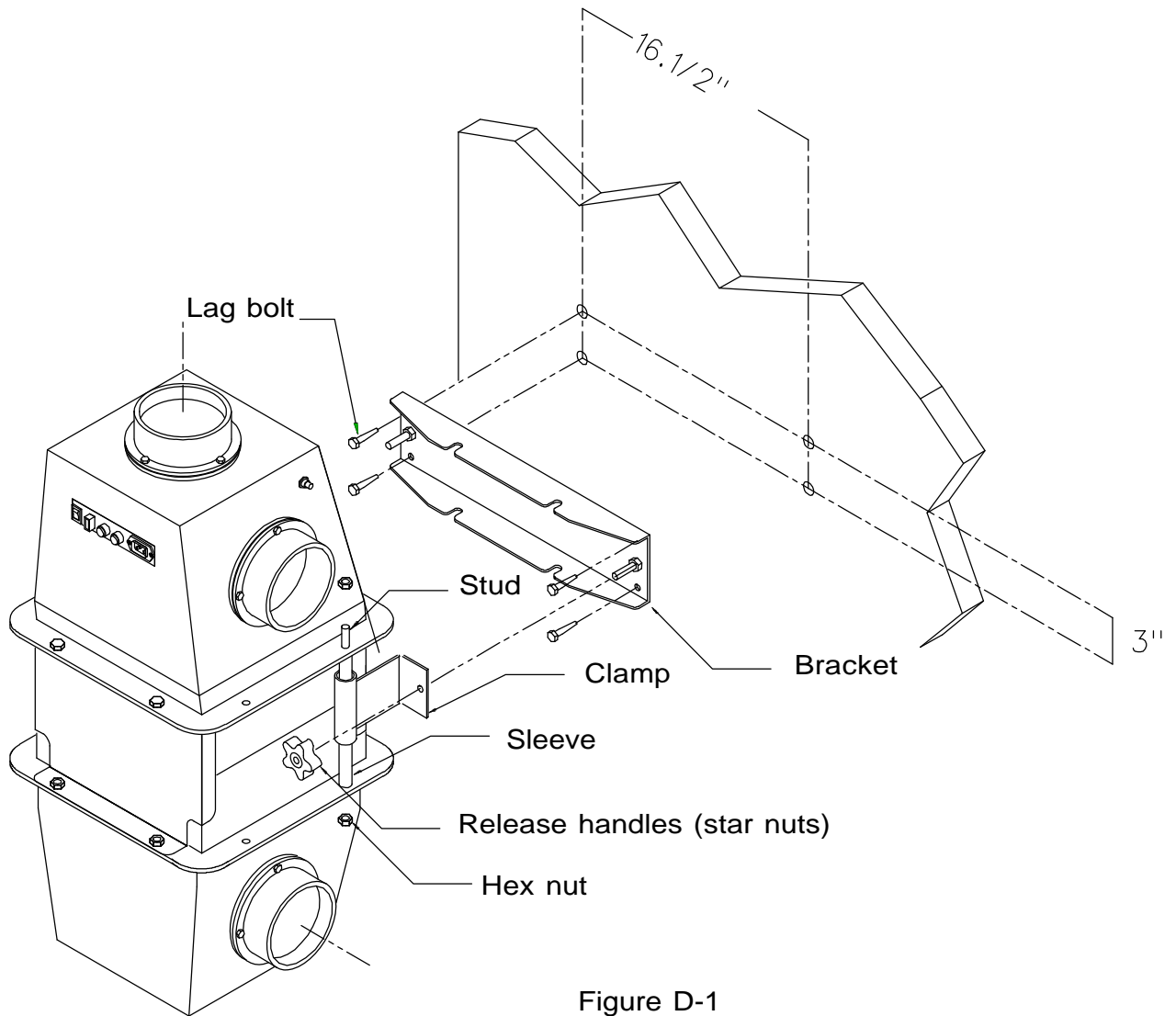

Figure D-1

# Installation

Mount the wall flange over the air intake hole in the wall or ceiling.

Remove the cap plugs from the intake and output ports.

Install the intake hose — a slight twisting motion may help to seat it onto the intake port.

## CAUTION

The hose couplings and hand pump are held in place by a shallow locking taper. Only a slight force is needed to secure a tight connection, do not over tighten.

In order to keep the filters fresh it is recommended practice to leave the intake and output port plugs installed in the Gaffco BDU-48 until use.

In the event of a nuclear, biological, or chemical event, removal of the cap plugs and reconnecting of the hose only requires a few seconds.

### AC electrical power

Connect the power cord to the control panel power socket and plug into a working power source (electrical outlet). Switch on the lighted main power switch on the front control panel.

### Automatic battery back up

Connect the 12-VDC cable connector to the control panel socket and connect the clip leads (jumper cable style clips) to a 12-volt DC automotive or marine type battery.

## CAUTION

Ensure that the positive clip lead (+) is to the positive post of the battery (+).

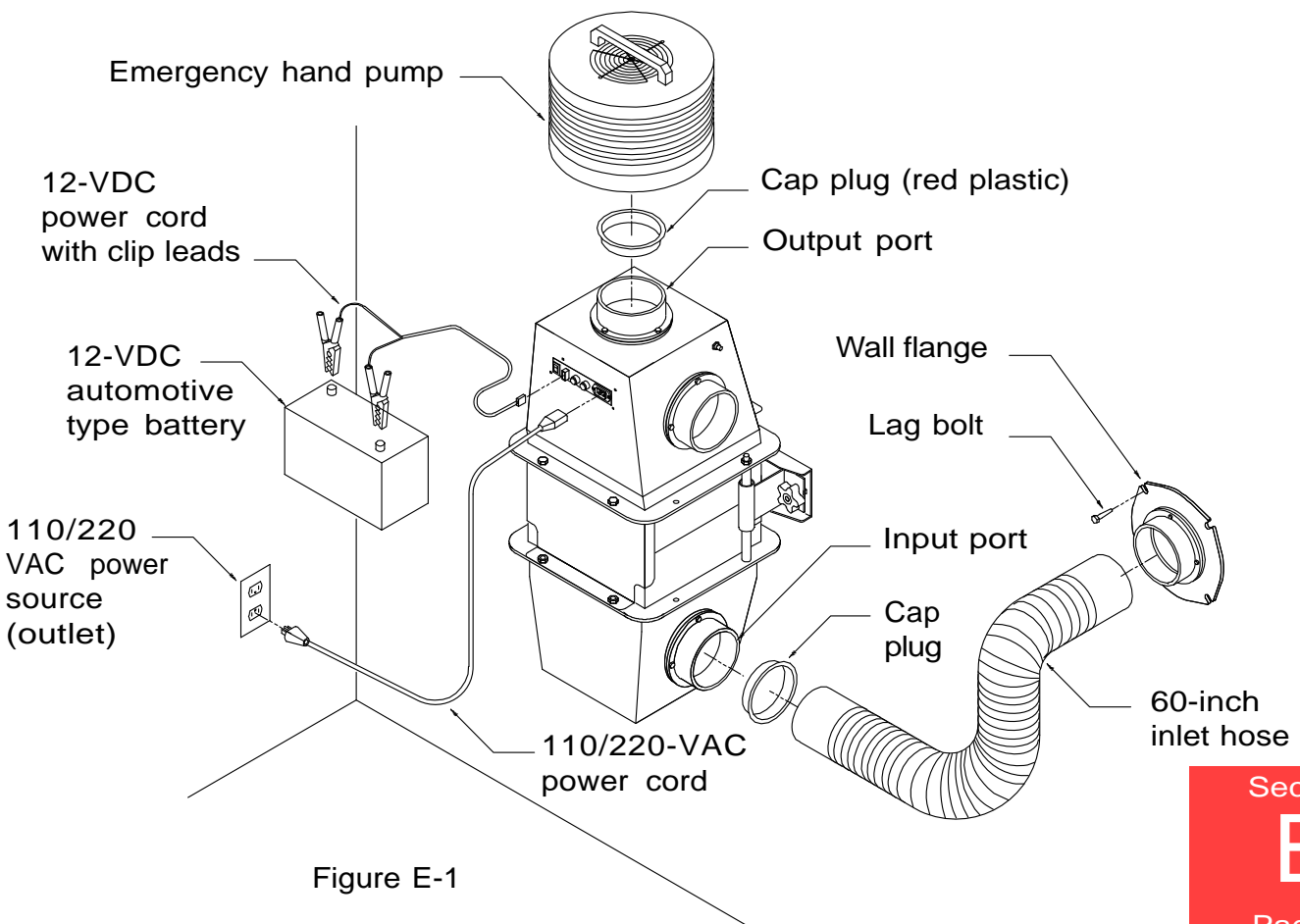

Figure E-1

## Operation — using the Gaffco BDU-48

Switch the lighted power switch on the control panel to the “on” position. This switch turns the internal power supply on and off — if it is in the “off” position, the blower (fan) will not be able to be turned on and the battery will not be automatically charged.

If necessary, push and release the blower control button on the right hand side of the top end bell so that the blower starts. Once the lighted power switch is in the “on” position, the blower control button will turn the blower on and off.

### CAUTION

Never allow the battery clip leads (clamps) to touch one another or anything that will conduct electricity between them at the same time. Allowing the battery jumper clip leads to cross while connected to the control panel battery socket will burn out the 7-amp fuse.

### CAUTION

Lead/acid batteries release hydrogen gas when they are being charged. Use only sealed sealed batteries inside of sealed rooms.

### Using the optional auxiliary hand pump

The emergency backup hand pump will displace (introduce into your protected space) about  $\frac{3}{4}$  cubic feet of air per full stroke. Overpressure can not be maintained with the hand pump alone, but sufficient filtered air can be pumped into the room in order to replenish oxygen supplies and displace the carbon dioxide. Please note that 3 cubic feet per minute of air per person is the minimum requirement.

If your Gaffco BDU-48 is mounted high up on the wall, leave the intake hose connected and remove the filtration unit from the wall bracket by removing the two star nuts on each side of it and place in a vertical position on the floor with output port facing upwards.

Using a slight twisting motion seat the tapered blower connection firmly over the output port of the filtration unit.

Using the handle on top of the hand pump, pull up and then push down repeatedly. You should feel air discharge around the handle on the down stroke.



# Operation — illustrations

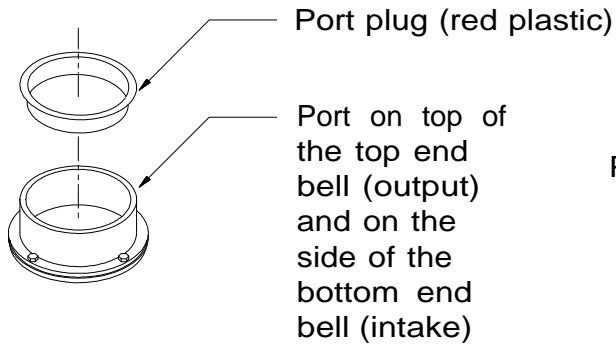

Figure F-1

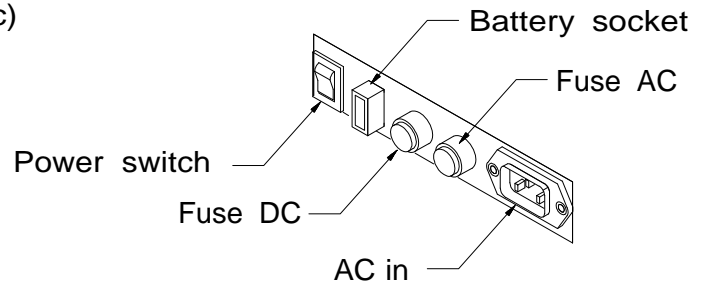

Figure F-2

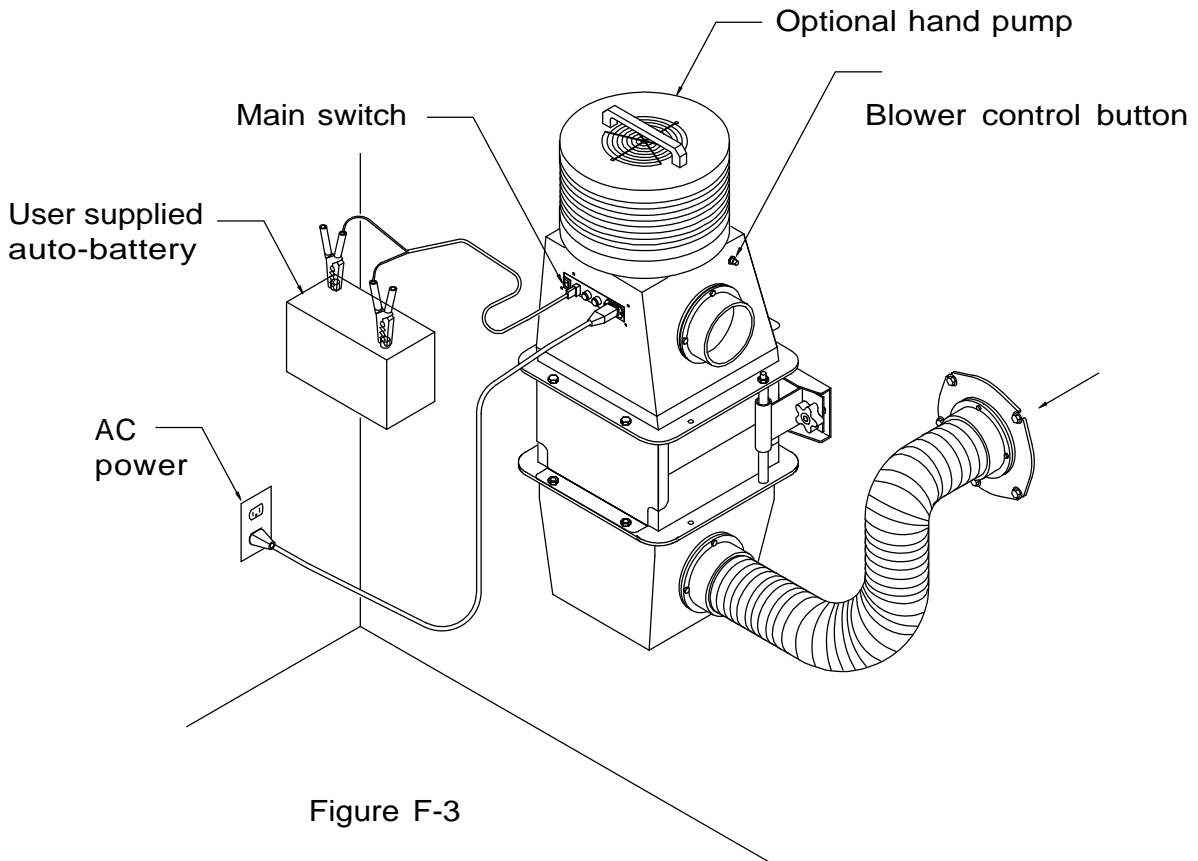

Figure F-3

# Operation — Bypass Mode

Using the fresh air by-pass system

## CAUTION

The filtration unit does not filter toxins from the incoming airstream when the intake hose is connected to top bypass port as shown below.

The fresh air bypass system will only provide unfiltered air into the sheltered space. This feature may only be used when no outside airborne toxic threat is present. It's purpose is to provide ventilation into the protected space when there is no threat present.

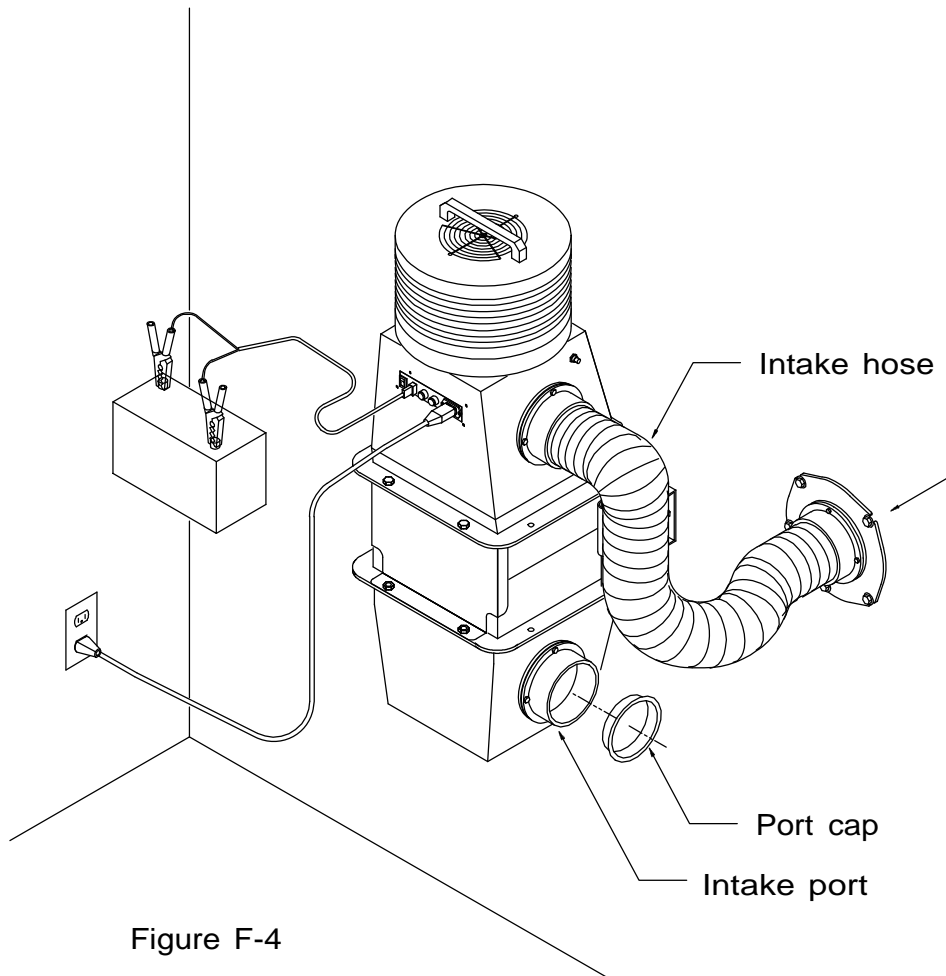

Figure F-4

1. Disconnect air intake hose from bottom end intake port
2. Remove top bypass port cap
3. Connect the air intake hose to the top bypass port with a slight twisting motion — do not overtighten
4. Insert port cap in bottom intake port to seal it up

## How the Gaffco BDU-48 works

The filter/ventilation unit intakes unfiltered air and pumps it into the protected space as filtered air causing a slight differential overpressure in the protected space relative to unprotected space.

This overpressure in the protected space dictates that all air leaks are outward, not allowing contaminated air or toxins to bypass the filter/ventilation unit and migrate into the protected space.

We recommend that the protected space have a minimum overpressure of .02 inches of water column and a maximum not exceeding .06 inches of water column.

The following text regarding overpressure is taken from the U.S. Army Corps of Engineers document Design of Collective Protection Shelters to Resist Chemical, Biological and Radiological (CBR) Agents, # ETL 1110-3-498.

### Definitions:

Toxic free area (TFA) same as meaning as Protected space or Safe Room.

Chemical, Biological and Radiological (CBR) same meaning as Nuclear, Biological and Nuclear (NBC).

### D-5. Toxic-Free Area Overpressure.

For existing facilities being modified or new facilities being designed with a Class II CP system, the air intakes will be protected with a CBR filtration system.

The TFA will be designed for a minimum overpressure goal of 5 Pa (0.02 inches wg).

This overpressure corresponds to a wind speed impact pressure normal to a wall of 12 km/hr (7 mph).

This wind speed condition is most favorable for directing a plume of agent with minimum dispersion toward an outside air intake.

# Testing the system

## General discussion

The Gaffco BDU-48 is only one component of a space protected from airborne pathogens. Others include proper sealing of the space and the release of overpressure in a metered amount. Your protected space should be envisioned as a pressurized vessel with a calibrated release valve. The overpressure ensures that all air enters only through the filtration system and the output ensures that you have true ventilation that introduces oxygen that the occupants need to inhale and removes the carbon dioxide that the occupants exhale. If you have a well sealed protected space, we recommend that you install one of our overpressure relief valves to meter the outflow of air in a known, calibrated quantity. See Section I for more information about the overpressure relief valve.

## Test number one: the negative pressure test

The purpose of this test is to insure that all unprotected rooms and space that surround the protected space are in fact at a lower air pressure than the actual protected space.

To conduct this test simply place in a safe manner lighted scent punks in the surrounding unprotected rooms for a period of 5 to 10 minutes while the Gaffco BDU-48 is in operation. No scent should be detected in the protected space.

## Test number two: the positive pressure test

The purpose of this test is to insure that all of the air in the room is escaping outwards through the cracks around the doors and windows.

To conduct this test, shadow the cracks around the doors and windows with a lighted smoke punk and observe the direction of the smoke draw:

Smoke drawn outward through a crack indicates the venting of positive pressured air from the protected space. This condition is allowable and indicates that the system is working properly.

Smoke rising off the smoke punk and is neither drawn out through the crack or blown back into the protected space. This condition is allowable and indicates that the crack is sealed.

Smoke blows back into the protected space the crack. This condition is unallowable and indicates insufficient overpressure in the protected space. This indicates that the system is improperly installed or that the room requires additional sealing.

## Changing the filters

Do not ever attempt to change the filters during an NBC event. Wait until it is over and you have credible indications that the outside atmosphere is safe to breath.

Once the event has been confirmed by the proper authorities that it was nuclear, biological, or chemical, all of the filters should be changed to remove the toxins trapped inside them. This includes the pre-filters, the HEPA filter, and the carbon adsorber.

Filters that are known or suspected of being used during an NBC event are considered hazardous waste and should be disposed of appropriately.

This disposal should be done in accordance with all laws and regulations governing hazardous waste disposal. Do not attempt to bury or incinerate used filters. Groundwater leachette (liquid that contains toxic chemicals) is very hazardous and smoke or fumes that are given off during burning may be hazardous if allowed to come into contact with the skin or inhaled into the lungs.

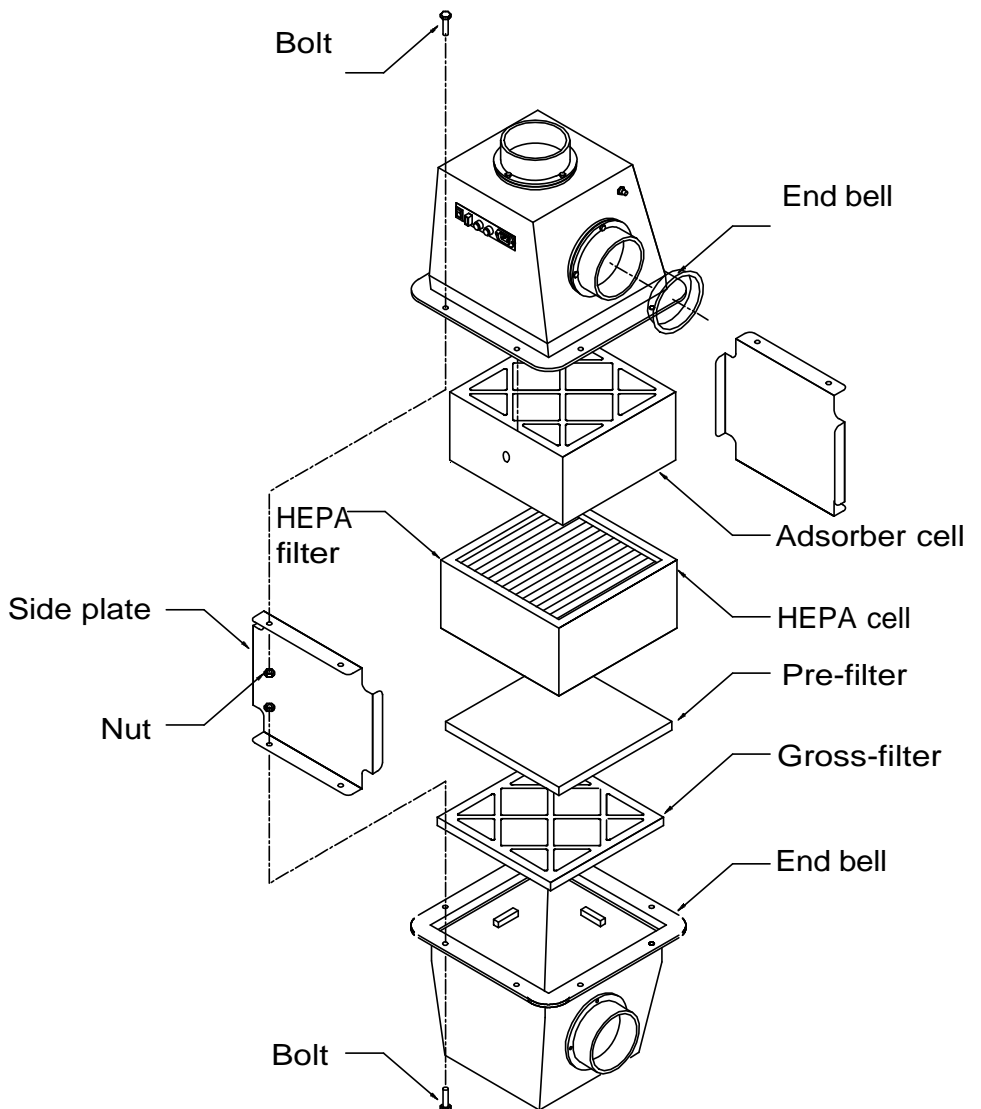

Figure I-1

Your Gaffco BDU-48 filter/ventilation unit employs a compression seal clamping mechanism to insure an even compression force of 20-PSI on the face of the filter seals.

To change the filters:

1. Remove the 8 clamping bolts and nuts on the side plates
2. Remove the 2 side plates
3. Remove the top end bell
4. Remove all of the filter elements
5. Wipe clean and inspect the end bell interiors and the sealing surfaces on them

To install new filters repeat steps 1 through 4 above in reverse order.

Replacement filters should be obtained from Gaffco Ballistics, LLC. Alternate sourcing of filters is not recommended and removes Gaffco Ballistics, LLC from liability resulting from inadequate performance by third-party filters.

## Optional hardware

### Connection kits

We manufacture the most commonly needed connection kits for connecting your Gaffco BDU-48 filter/ventilation unit to an external air supply.

These kits may also be used where an air exhaust port is required for sealed rooms or bunkers that employ the overpressure relief valve.

All of the connection kits accept the quick connect hose coupling of the filter/ventilation unit or the mounting of the overpressure relief valve when an exhaust is required.

### Backup hand operated air pump

The Gaffco BDU-48 filter/ventilation system is equipped with an internal automatic switching power supply. This system automatically switches the BDU-48 to the user-supplied 12-volt automotive battery in case of failure of the main AC power.

Please note: most fully charged 12-volt automotive or marine type batteries will operate the unit for 16 to 24 hours.

For your added safety in case of a long term electrical power failure we manufacture the auxiliary emergency backup hand operated air pump. This part slip-fits directly on top of the BDU-48 and can be installed and put into operation in a few seconds.

### Overpressure relief valves

Used when the Gaffco BDU-48 filter/ventilation unit is installed into a location that provides no other means for expelling the carbon dioxide ( $\text{Co}^2$ ) that occupants exhale. It meters the air out in a controlled quantity to maintain overpressure and provide true ventilation (air in/air out)

These well sealed protected spaces usually include concrete safe rooms, underground bunkers or steel enclosures. Most residential and commercial homes and buildings are not sealed up enough to warrant an overpressure valve - but this needs to be determined by testing the protected space after the installation of the BDU-48. If you have a protected space that is not properly sealed, taking additional measures to seal it up and installing an overpressure relief valve is the best way to ensure your safety—air should have one way in (through the filters in the BDU-48) and one way out (metered through the overpressure relief valve).

### Automatic two way explosion resistant blast valve

The automatic two way blast valve offers external blast protection up 7,200 pounds per square foot for use in hardened shelters. This rating is for both pressure and vacuum.

### Test kit

The test kit provides a means to verify that all of the components of the BDU-48 ventilation system are working properly.

### Differential pressure monitor

Provides a highly accurate digital readout of differential room pressure in real time.

Section

J

Page 14

# Component dimensions

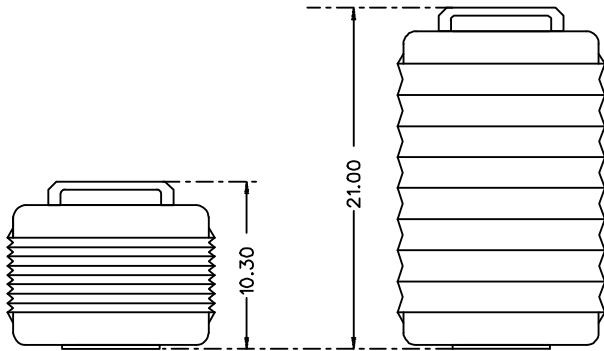

Figure K-1  
Manual hand pump

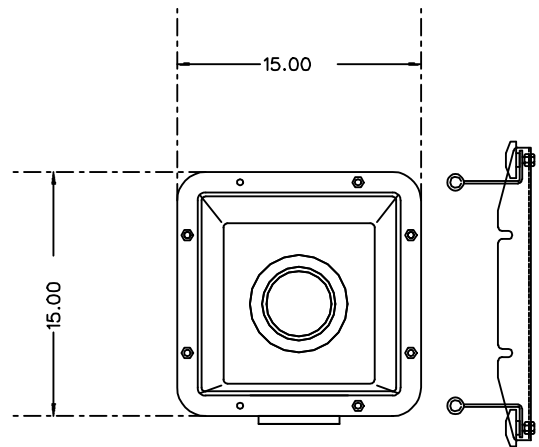

Figure K-2  
BDU-48 top view

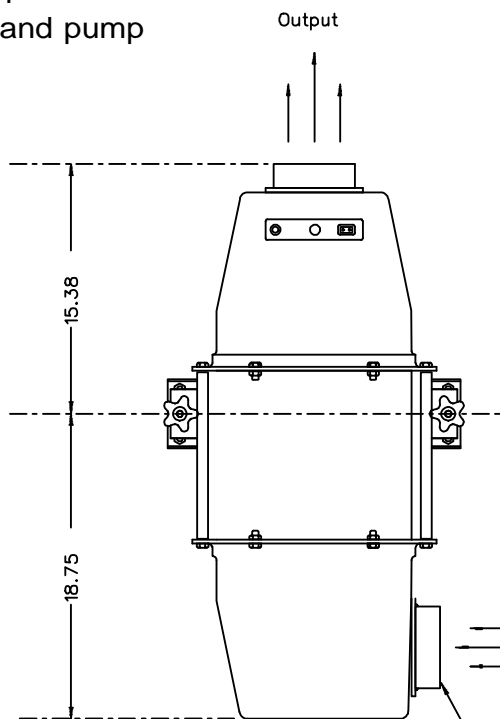

Figure K-3  
BDU-48 front view

Intake hose coupling

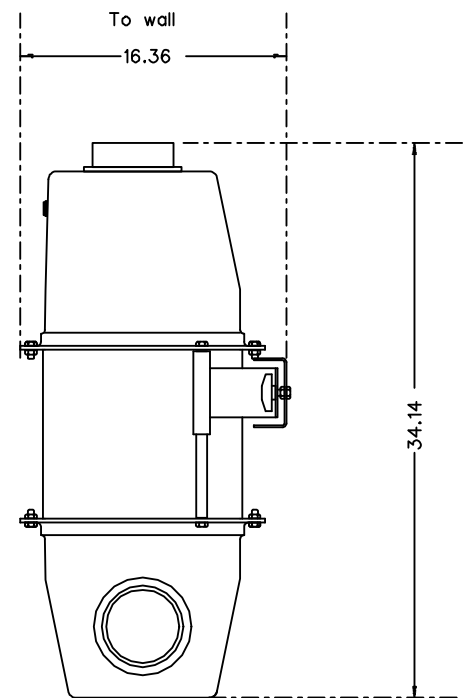

Figure K-4  
BDU-48 side view

## Specifications — general

### **Gaffco BDU-48**

Size:	380-mm/15 inch square x 867-mm/35 inch high
Weight:	22 kilograms/49 pounds with all filters installed
Blower output:	7-cubic meters per minute/250-cubic feet per minute
System output:	100 cubic meters per hour
Noise level:	60 DB A scale
Voltage:	120 to 240 volts/50-60 hertz and 12-VDC battery back up
Amperage:	2.5 amp at 110-220VAC, 4.4 amp at 12 vdc
Fuse AC:	4-amp
Fuse DC:	6-amp
Power cords:	US standard 110-VAC grounded plug and a clip-lead 12-VDC cord (battery) or optional Israeli, UK or other (specified by country of use)
Flexible hose:	127-mm/5-inch diameter. 1.5-meter/60-inch long



# Specifications — filters

## Filters

Two piece pre-filter: Protects HEPA against larger airborne particles.

The first part is a rigid polymer matrix of .

Second part spun fiberglass pad.

## HEPA aerosol filter

Protects personal against poisonous aerosols and biological warfare agents.

## CERTIFIED TO MEET OR EXCEED MIL F 51079-1998

The nuclear grade media furnished in these filters is certified to meet the requirements of the: Israeli Ministry of Defense and the U.S. Army.

MIL-F-51079D as required in the US Army document for:

Design Of Collective Protection Shelters To Resist Chemical, Biological and Radiological (CBR) Agents, Us Army Corps of Engineers ELT 1110-3-498 24 Feb. 1999.

EN 1822-1-1998 High efficiency air filters: Classification, Performance testing and marking.

Media	Water repellant glass micro fiber 99.97% true HEPA type (A).
Cell Side Material	Fire retardant particleboard
Separators	Aluminum
Bond:	Polyurethane foam
Gasket Material	Neoprene (RE43E1)
Gasket Location	Both sides
Factory Test	Certified 99.97% (DOP)
UL 866 Label	Required

## HEPA filter cell

As developed by the Atomic Energy Commission and used in nuclear power stations, hospitals and bio-containment laboratories.

## Guaranteed Performance

Each HEPA filter is individually tested before it leaves the factory, your assurance that it meets rated efficiency. The penetration and actual airflow rate are indicated on the label. Each filter is also assigned a serial number.

# Specifications — standards

## DOP Test

This has been the industry standard test method for many years. It is conducted using a forward light scattering photometer. The HEPA is challenged with 0.3 micrometer particles of dioctyl-phthalate (DOP). By measuring the upstream and downstream concentration of these particles, the HEPA filter cell efficiency can be calculated.

## Underwriters Laboratories Classification UL 586

This classification to insure that each HEPA filter cell is individually tested at the factory. Additionally, representative HEPA filter cells are tested by UL to ensure that they provide their rated HEPA level filtration, after being subjected to the following conditions of a high moisture environment of (90% R.H.), a high temperature environment of (371 degrees Celsius), low temperature environment of (-3 deg/C). UL also subjects the HEPA filter cell to a spot flame test of 954 degrees Fahrenheit.

## Activated carbon filter for protection against war gases

The nuclear grade war gas adsorber is a block sieve filter cell consisting of two containment medias and a block of nuclear grade war gas carbon.

It is effective in the removal of the following war gases:

- Hydrogen cyanide
- Phosgene
- Mustard gas
- Sarin
- Ricin
- VX

## NUK-TK Nuclear Grade Carbon Specifications

### Cell size

304-mm/12-inch sq x 152-mm/6-inch deep.

### Carbon, activated impregnated TEDA copper-zinc-molybdenum-triethylenemelamine

- |                      |  |
|----------------------|--|
| 1. ASTM D 2854-1996  | Standard test method for apparent density of activated carbon  |
| 2. ASTM D 2867-1999  | Standard test method for moisture in activated carbon          |
| 3. ASTM D 3802-1997  | Standard test method for ball-pan hardness of activated carbon |
| 4. ASTM D 3467       | Activity for CCL: 60% minimum                                  |
| 5. ASTM D 2862/D5158 | Particle size: 4 x 8 Mesh U.S.                                 |
| 6. ASTM D 3838       | pH aqueous extract: 9.2 minimum                                |
| 7. ASTM D 3466       | Ignition temperature 330 Celsius                               |
| 8. ASTM D 3803       | Radioactive iodine removal                                     |
| 9. Impregnate        | 2.1 Potassium iodide, 3.1% TEDA                                |

# Specifications — occupant ratings

The Gaffco BDU-48 produces 60 cubic feet per minute of filtered air supply sufficient for 12 adults.

The above ventilation requirements in shelters are based on the two ASHRAE standards shown below. The higher of the two standards is the one we use.

In order to insure sufficient airflow rate and overpressure state in a particular installation the guidelines specified in the installation manual and test kit must be followed.

Some installations require larger unit sizing based on the size and construction type of the room rather than the number of occupants.

Please do not hesitate to contact our technical support department with any questions.

We highly recommend adherence to local building codes.

ASHRAE Handbook 1985 Fundamentals Volume  
Section IV Load and Energy Calculations

Chapter 22 Ventilation and Infiltration

(TC 4.3, Ventilation Requirements and Infiltration)

Page 22.1 Minimum Outdoor Air Supply Rates:

ASHARE Ventilation Standard 62-1981,1 defines minimum outdoor air supply rates for various types of occupancy. These rates have been arrived at through a consensus of experts working in the field. As shown in Eq. (2), a minimum rate of 5 cubic feet minute per person for sedentary activity and normal diet holds the  $Co^2$  level in a space 0.25% under steady state conditions.

While normal healthy people tolerate 0.5%  $Co^2$  without undesirable symptoms and nuclear submarines sometimes operate with 1%  $Co^2$  in the atmosphere, a level of 0.25% provides a safety factor for increased activity, unusual occupancy load or reduced ventilation.

ASHRAE HANDBOOK 1982 APPLICATIONS  
Environmental Control for Survival 11.1-11.24

Page 11.4 Vitiation Factors:

Carbon dioxide concentration should not exceed 3% by volume and preferably should be maintained below 0.5%. For a sedentary man, 3 cfm (1.4 l/s) per person of fresh air will maintain a  $Co^2$  concentration of 0.5%.

Section



Page 19